

THORN

Contrast LED and Qba LED

Advanced architectural floodlighting
combining practicality and creativity





Which LED floodlight gives designers exceptional flexibility in the specification of wall washing illumination?

Qba LED

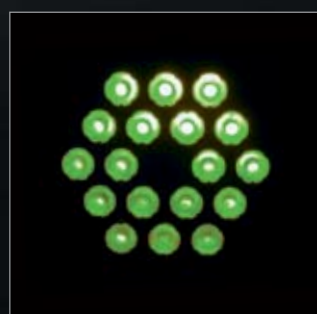
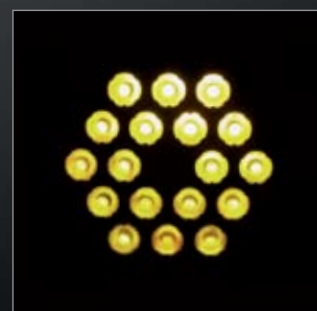



Which LED floodlight has the power to project light up to 30m, yet can produce a variety of precise beam distributions?

Contrast LED

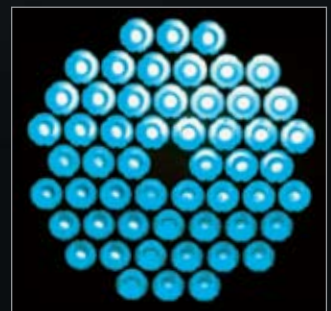
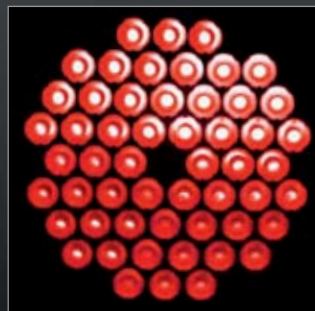

Qba LED

Engineered for long life, and highly energy efficient, Qba LED offers a choice of colours and controls which enables creative lighting schemes to be implemented quickly and easily.

All Qba LED floodlights can easily be combined with other Qba products, allowing existing installations to be augmented with confidence. Similarly, new projects can combine any Qba luminaires to leverage the product range's uniform light shapes and outputs.

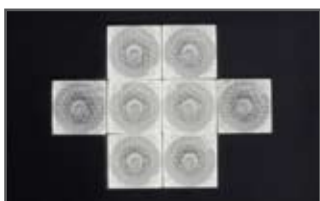

Efficient LEDs for wall washing applications:

- 18 LEDs for monochromatic versions (from +/- 5.6° to 6.6° beam)
- 8 multichip LEDs for the RGB version (12° beam) for better colour mixing

IP66/IK08 floodlight

Easy to combine with conventional Qba floodlights

DMX connection card integrated for the RGB version

Integral gear for all versions



Additional knockout for through wiring (available on request)

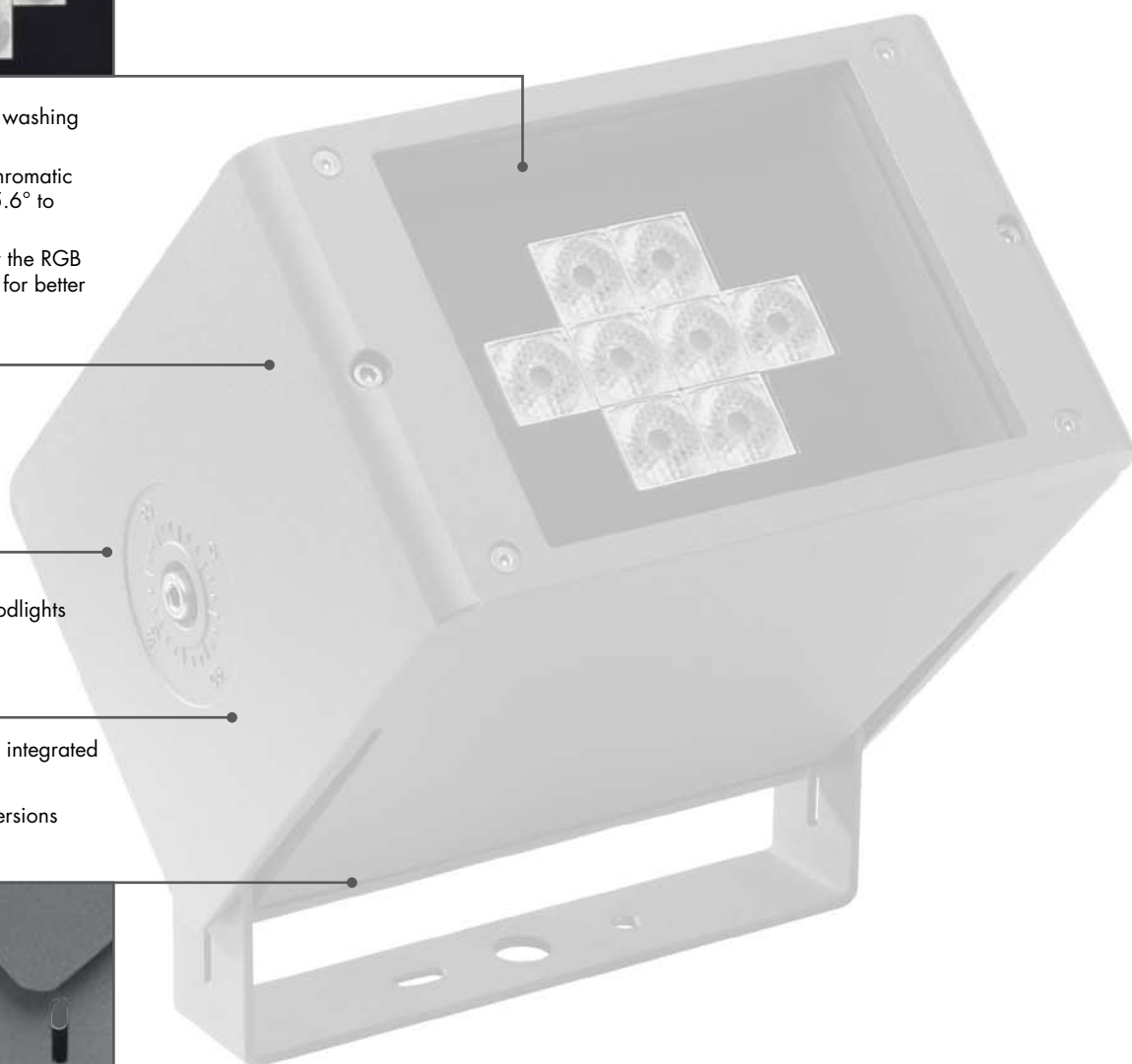

Contrast LED

The newest addition to Thorn's versatile range of floodlighting fittings, Contrast LED is ideal for use on architectural features and decorative areas. It produces exciting lighting and coloured effects without wasteful spillage onto surrounding details.



Using the Contrast size R0 front frame, the Contrast LED is compatible with all existing accessories (except honeycomb louvre)



Distinctly styled, ultra-modern design with heat dissipation fins to maximise heat transfer and to ensure the life time of the LEDs



Intensive LED technology for efficient light beam ($\pm 4^\circ$)

- 54 LEDs for monochromatic versions
- 36 LEDs for RGB and RGBA versions

Slim circular shape for easy integration

IP65/IK08 floodlight body

Pre-wired floodlight for easy installation



A Gore-Tex® screw-in vent constantly allows the floodlight to breathe with changing environmental conditions, eliminating condensation and ensuring an IP65 seal



IP66/IK08 remote connection box with self retaining screws

Performance, Efficiency and Comfort (PEC) – for a better lit environment

Contrast LED and Qba LED evoke the spirit of Thorn Lighting's dynamic, results-orientated PEC programme

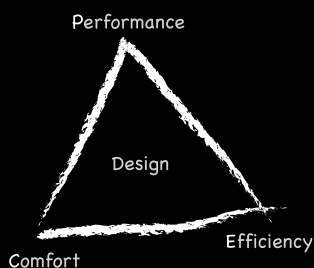

The programme is based on the principle that Performance, Efficiency and Comfort determine the effectiveness of lighting, its impact on the people using it, and its impact on the natural environment. Contrast LED and Qba LED deliver the right light on the right place at the right time.

Performance: Providing the best visual effectiveness

- The highly uniform and precisely controlled floodlight beam allows designers to produce applications with good modelling properties, revealing features and patterns in the lit scene.
- The combination of intensive LEDs and versatile attachments enables designers to enjoy a uniform beam with excellent modelling qualities, as well as an infinite number of light effects in a choice of colours and colour temperatures.

Efficiency: Conserving energy and effort, reducing CO₂ emissions and waste, providing lighting that is practical and efficient to install, operate and maintain.

- Contrast LED and Qba LED are easy to install and aim. All accessories are supplied ready to fit and to attach to the front frame without the need to open the floodlight body.
- LEDs offer a long operating life as well as good energy efficiency. Lamp replacement is not required, minimising the need for maintenance and reducing the cost of ownership of the luminaire.
- The intensive collimated lenses and optical attachments ensure that there is no waste illumination.
- Unlike conventional light sources LEDs contain no mercury and emit no UV or IR radiation, providing a more environmentally friendly solution.

Comfort: giving people satisfaction and stimulation

- RGB LEDs combined with dynamic mixing allow variety in the lit scene, from a calm and relaxing atmosphere to a lively, stimulating environment.
- The discrete design of the Contrast LED and Qba LED floodlights make them inconspicuous by day, blending in with the day lit architecture of a space. Additionally by maintaining current Contrast and Qba designs they can easily be integrated into existing schemes which use conventional Thorn projectors.



Left

Contrast LED RGB x 3
Contrast LED warm white

Right

Contrast LED blue with LR2 refractor
Contrast LED blue with OMW prismatic glass

Qba LED warm white x 2
Band Extensive white



Qba LED light effects

For wall washing applications Qba LED provides an intensive light beam which can be designed with the addition of a refractor with vertical prisms (filter 555B V - SAP code 96220097).

For an offset application two refractors are offered: with vertical prisms for horizontal light beam orientation (filter 555B V - SAP code 96220097) and with horizontal prisms for vertical light beam orientation (filter 555B H - SAP code 96220098).

Right

Contrast LED warm white with LR1 refractor

Qba LED cold white x 2
Band Extensive white

Measurements made on cold white 6000K version - 18 LEDs

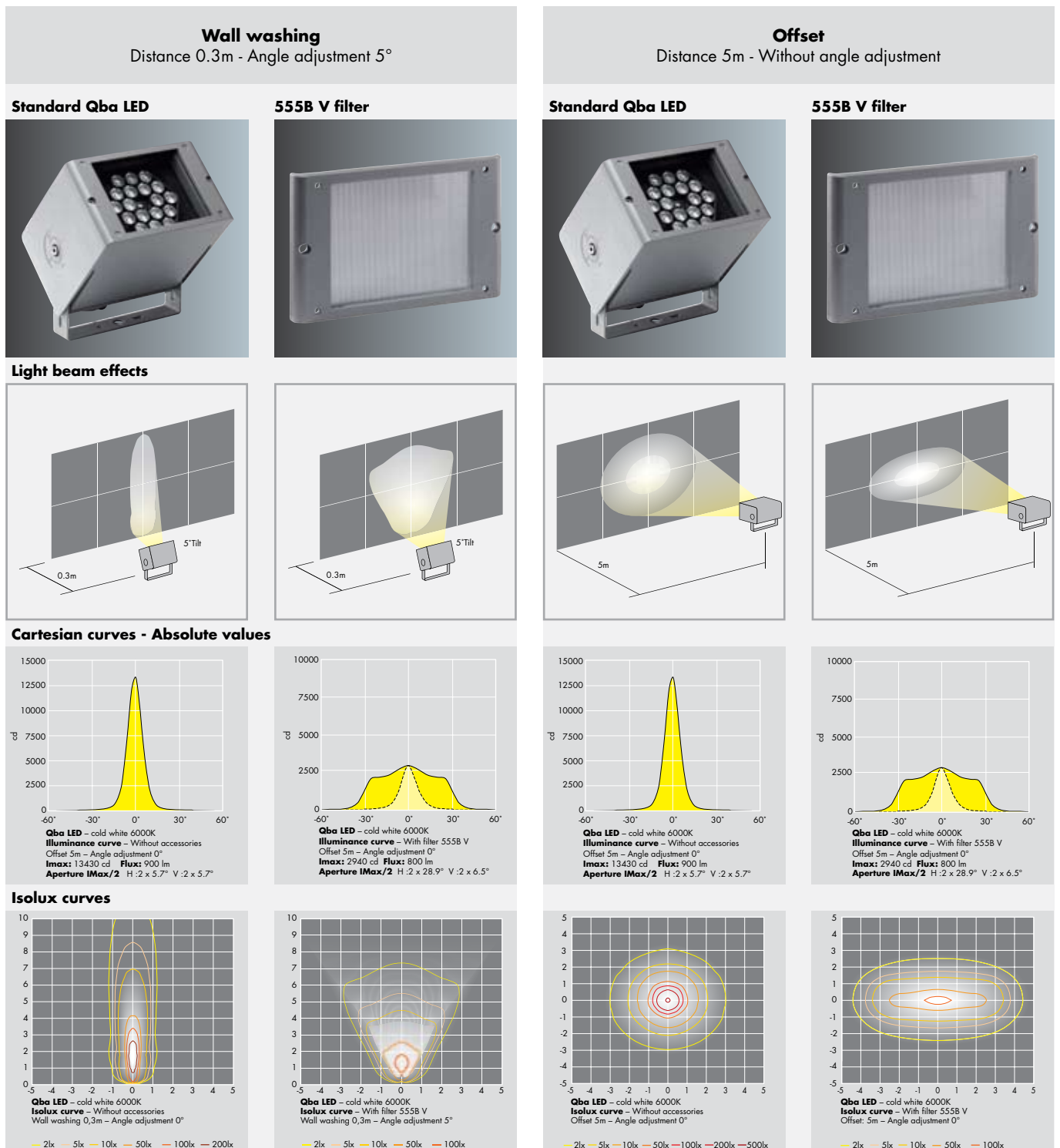



RESTAURANTS

Contrast LED light effects

Contrast LED presents huge opportunities for the expression of form, colour, contrast, and design - all the things that add a creative dimension to our environment. It provides designers with a way to achieve new and stimulating perspectives.

Refractors

These can be rotated to align the beam profile to suit the application.

Measurements made on cold white 6000K version - 54 LEDs

Offset Distance 10m - Without angle adjustment

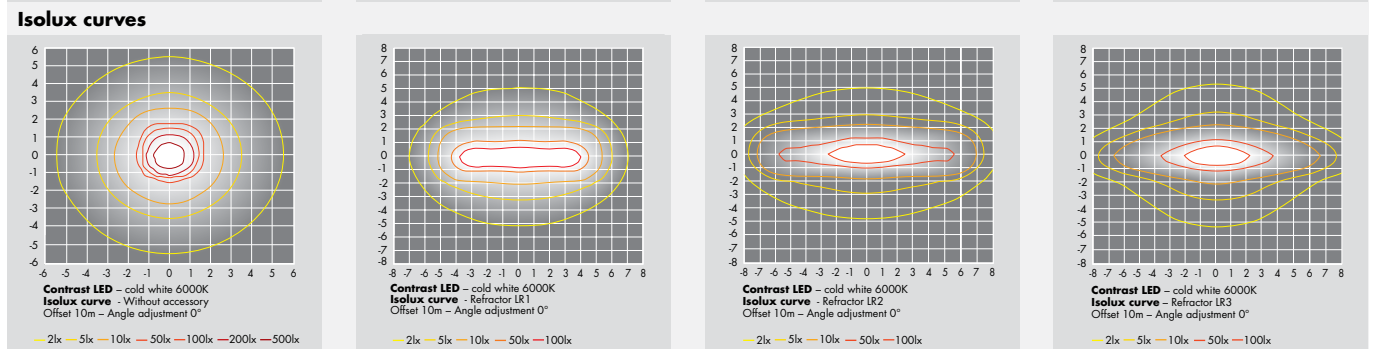
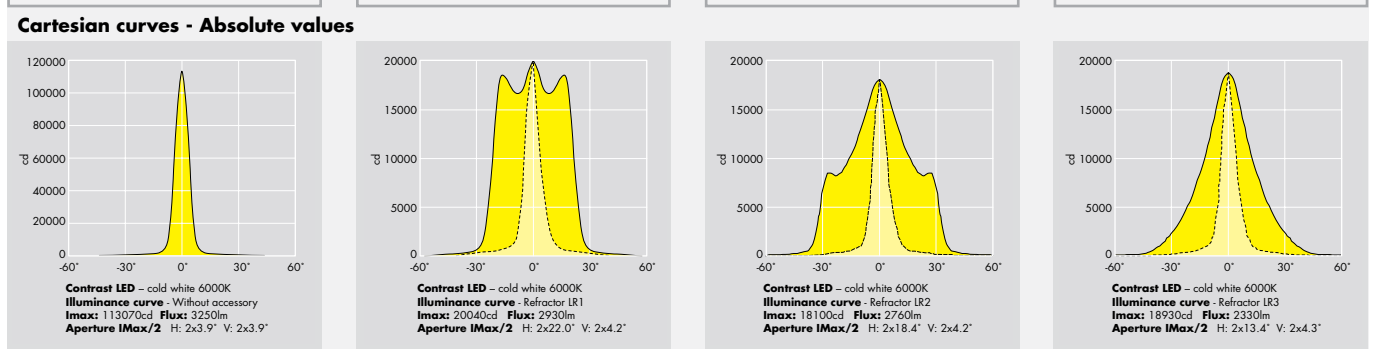
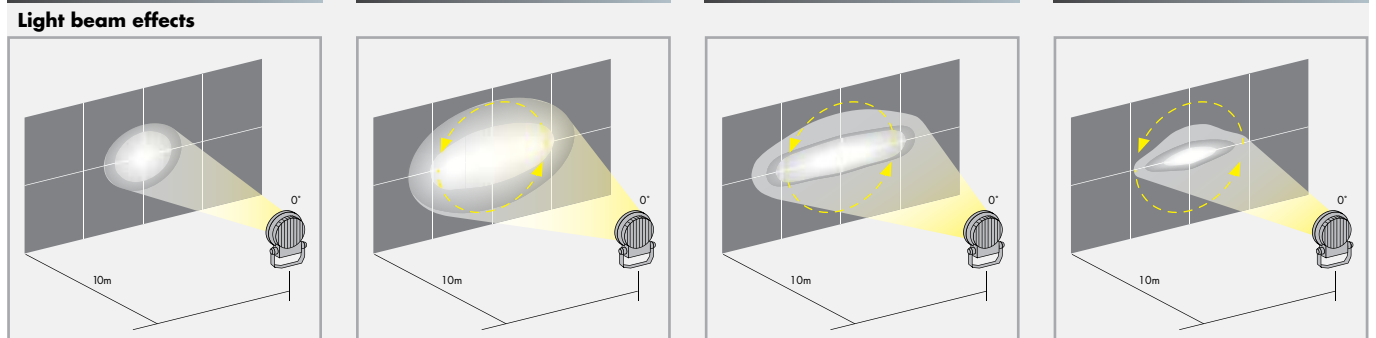
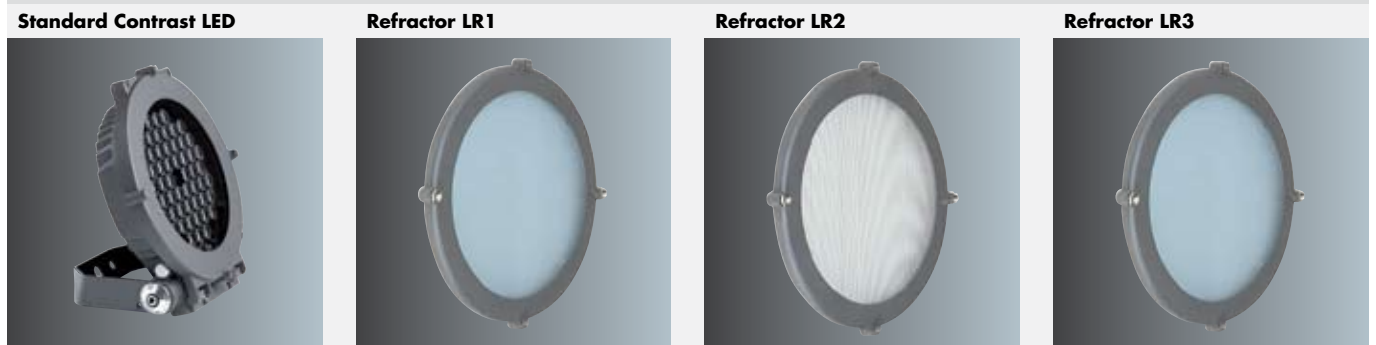

Prismatic glasses

These can be rotated to give alignment of the beam profile to suit the horizontal or vertical structure.

Measurements made on cold white 6000K version

Offset

Distance 10m - Without angle adjustment

OMS - Semi-intensive



OMP - Semi-extensive



OMW - Extensive



OME - Super extensive



Light beam effects

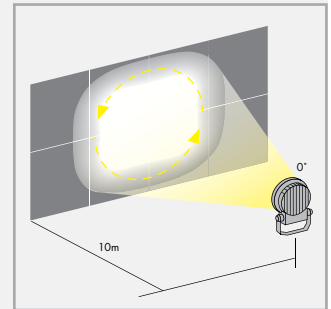
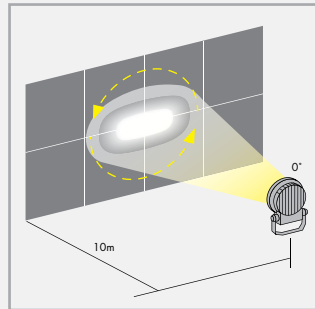
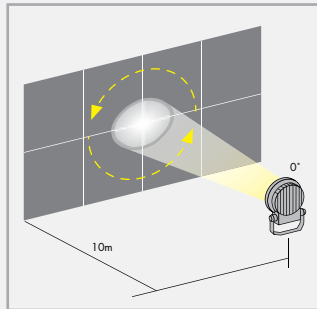
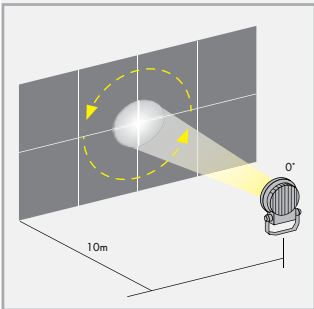

Cartesian curves - Absolute values

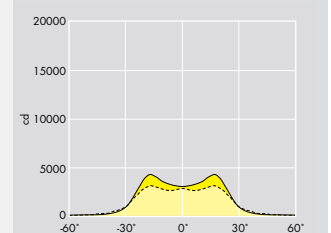
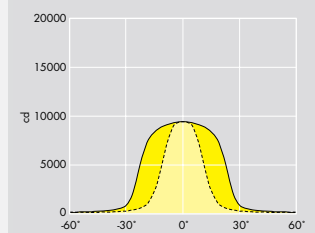
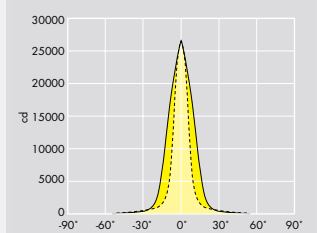
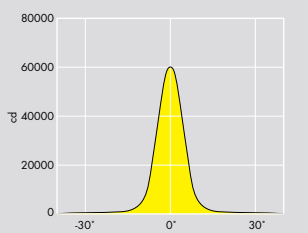

Isolux curves

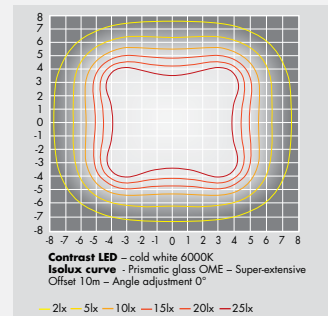
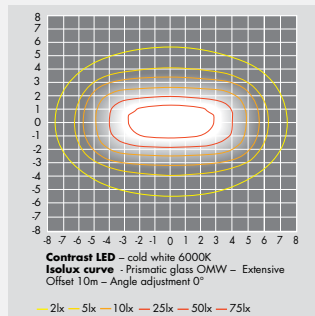
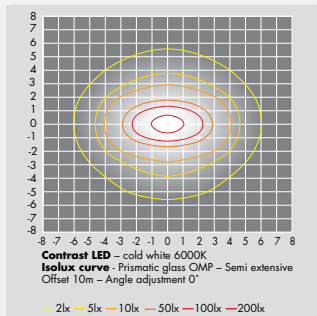
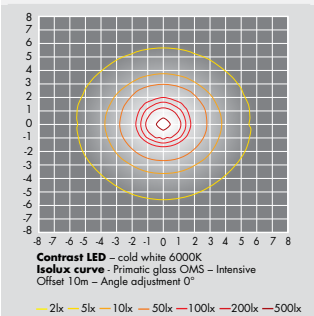

Contrast LED and Qba LED colour effects

Colours



Qba LED monochromatic

319 lumens

287 lumens

870 lumens

293 lumens

Contrast LED monochromatic

1225 lumens

1078 lumens

2738 lumens

1080 lumens - On request

Colour temperatures

Two different white versions - warm (3000K) and cold (6000K) support different effects on natural materials or buildings.

A glass chromatic correction filter can be added to the Qba LED or Contrast LED as an easy way to decrease the colour temperature on 6000K and 3000K. The result is 4700K (cold white + filter) and 2700K (warm white + filter) respectively.

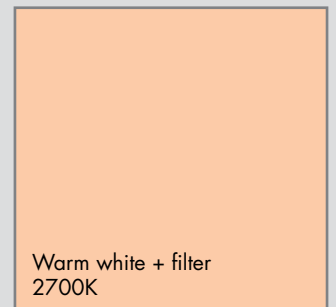
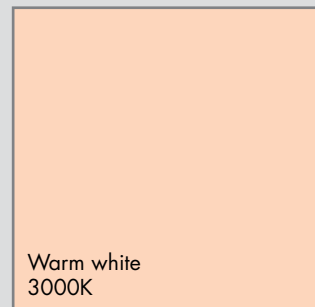

Qba LED

901 lumens

660 lumens

751 lumens

550 lumens

Contrast LED

3253 lumens

1984 lumens

2364 lumens

1450 lumens



Qba LED RGB

385 lumens

Contrast LED RGB

1222 lumens

Values measured with all the LEDs switched on.

The RGB versions are driven by DMX protocol (control system not supplied).



Qba LED chromatic correction filter



Contrast LED chromatic correction filter



DMX connection for Qba LED and Contrast LED RGB

If there is no need for special effects or synchronisation between multiple Contrast LED or Qba LED RGB floodlights, an automatic sequence can be played by setting all DMX switches to zero.

For lighting effects, the RGB Contrast LED or Qba LED versions needs a DMX signal provider like the Spectra Memory box (to be ordered separately, see below).

Used in conjunction with the 'Spectrasoft' software, it is possible to create and play scenarios. The Spectrasoft CD is installed on a PC. Once the programme has been installed, it is downloaded to the Spectra Memory box which stores and transmits the data to the projectors. After this the computer is not required except for any programme changes. The DMX signal is sent to the electronic address cards by DM512 cable into the connection box for the Contrast LED or directly into the Qba LED body.

The distance between the memory box (or the other DMX signal provider) and the last Contrast LED RGB/RGBA connection box or Qba LED RGB is maximum 300m with a maximum of 32 floodlights.

They are typical values which need to be confirmed by installer depending upon the project configuration. Even if you use quality cables and DMX line termination, electromagnetic disturbances may occur. To avoid these disturbances use a DMX booster to re-amplify the DMX signal.

If the distance between the memory box and the last floodlight is longer than 300m, a booster to re-amplify the DMX signal is required. The booster will be counted like a fitting. In this case, the maximum quantity of floodlights will be 31 + 1 booster.

The distance between 2 boosters is 300m maximum.

Boosters have 2 or 4 lines to create star wiring. Each line is considered as an independent line which can contain 32 floodlights.

On the final floodlight in the chain, a DMX line termination must be added to prevent the signal 'bouncing back' (into the connection box for the Contrast LED RGB and into the Qba LED rear for the Qba LED RGB).

DMX Control Ordering Guide

Description		Wt (Kg)	SAP code
CONT SPECTRA SIGNAL BOOSTER X2 FOR DMX		2.6	96009848
CONT SPECTRA SIGNAL BOOSTER X4 FOR DMX		3.0	96012407
CONT SPECTRA DMX LINE TERMINATION		0.1	96012408
CONTRAST SPECTRA MEMORY BOX (FOR SOFT)		1.7	96253059
CONTRAST SPECTRA SPECTRASOFT CD	Software	0.1	96012354
CONTRAST SPECTRA CAB DMX512	DMX cable sold per metre	0.1/m	96230866

Installation without booster and several Contrast LED RGB or/and Qba LED RGB

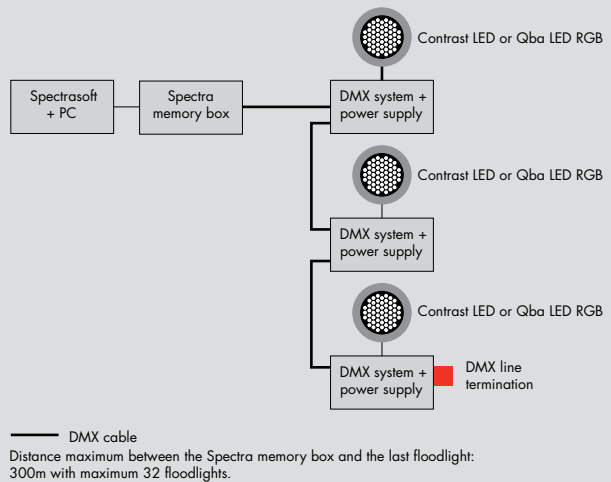

Installation with 1 booster and several Contrast LED RGB or/and Qba LED RGB

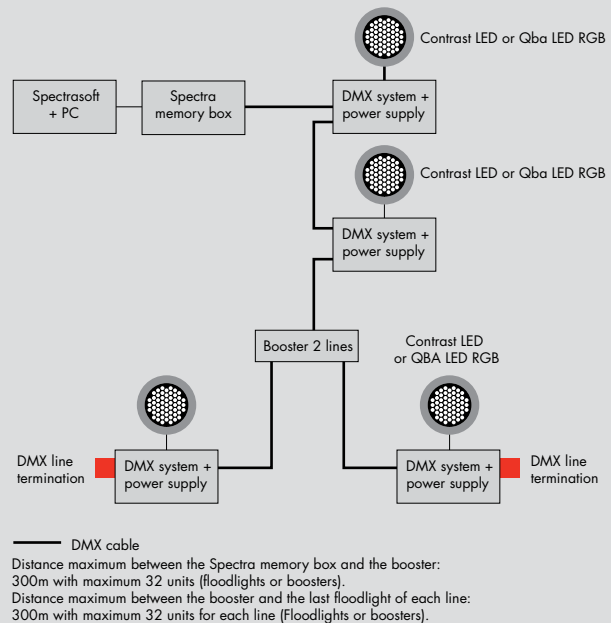

Qba LED



Monochromatic version



RGB version

LEDs

Monochromatic: 24W for 18 LEDs
 RGB: 36W for 8 multichip LEDs

Materials/Finish

Body, frame and accessories: die-cast aluminium ENAB44100 with textured grey powder coated finish
 Body screws: stainless steel
 Attachment retaining screws: nickel plated brass
 Front glass: toughened glass
 Alternative RAL colours on request

Installation/Mounting

Qba LED luminaires are adjustable on a stirrup. Aiming is simplified by an indicator on the body sides, locked via a central 8mmØ Allen screw. Short wall mounted stirrup also available as an accessory. To connect fittings, installers simply open the rear part of the luminaire to access the inside connector.

For electrical connection: cable gland for 6-11mm diameter cable. An additional cable gland for through wiring is available on request.

For the DMX connection (RGB version only) a DMX cable is required for creative effects. For DMX512 cable the connection requires two 7mm cable glands. Data+, data- and ground are routed to the DMX connector.

Standards

Designed and manufactured to comply with EN60598
 Class I electrical
 Class II electrical on request (monochromatic versions only)
 IK08/5 N/m impact resistance
 IP66
 CE

To specify state: Compact rectangular LED floodlight for wall washing. Die-cast aluminium body with concealed stirrup. Sealed IP66. With a choice of 6 monochromatic colours (2 white, Red, Blue, Green and Amber) and dynamic RGB employing LED light source with integral power supply for monochromatic versions or power supply plus DMX driver for the RGB version. Other DMX components ordered separately. As Thorn Qba LED.

Ordering Guide

One code includes the Qba LED with integral power supply for the monochromatic versions or power supply + DMX system for the RGB version

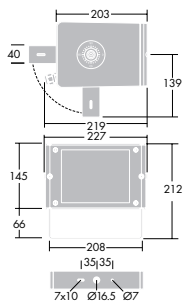

Description	Weight (Kg)	SAP code
Monochromatic versions		
QBA LED 24W 240V 18LED WHI/6000K	6.0	96254271
QBA LED 24W 240V 18LED WHI/3000K	6.0	96254272
QBA LED 24W 240V 18LED BLU	6.0	96254273
QBA LED 24W 240V 18LED RED	6.0	96254274
QBA LED 24W 240V 18LED GRN	6.0	96254275
QBA LED 24W 240V 18LED AMB	6.0	96254276
RGB version		
QBA LED 36W 240V 8LED RGB DMX	5.8	96254277



555B H filter



Visor



Louvre



Chromatic correction filter

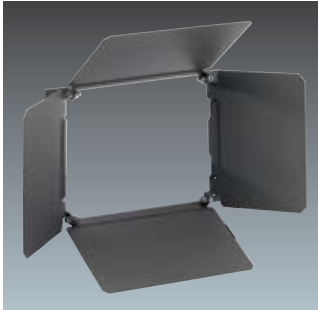

Barn doors



555B V filter



Wire guard

Accessories Ordering Guide

Description		Weight (Kg)	SAP code
QBA VS	Visor	0.4	96012228
QBA WG	Wire guard	0.4	96012229
QBA AGS (x4)	Set of 4 barn doors	0.8	96012230
QBA LV	Louvre	0.8	96012231
QBA FILTER REFR 555B V	Vertical prism	0.6	96220097
QBA FILTER REFR 555B H	Horizontal prism	0.6	96220098
QBA GL CHROMATIC CORRECTION FILTER	Warmer glass LEE filter 205	0.4	96254527
QBA SHORT STIRRUP	Wall stirrup	0.4	96012236

Contrast LED



Monochromatic version



RGB version

LEDs

Monochromatic: 86,6W for 54 LEDs body + power supply for Whites, Blue and Green. 60W for the Red version (and the Amber version on request).
 RGB: 51,6W for 36 LEDs body + power supply + DMX driver (and for the RGBA version on request)

Materials/Finish

Body and frame: die-cast aluminium, textured grey powder coated finish.
 Screw-in vents: Gore-Tex®, Polyvent/M12x1.5
 Screws: stainless steel
 Front glass: 4mm toughened glass
 Cable: 1.5m long rubber H07RNF 2x1mm² for monochromatic versions
 Profilplast CSA type 4x1mm² R for the RGB version (Profilplast CSA type 5x1mm² L for the RGBA version)
 Alternative RAL colours on request.

Connection box: Grey ABS/PC (Polycarbonate) RAL 7043, material coloured
 Gasket: silicon
 Cable gland: Brass
 Retained screws: stainless steel
 Control system: DMX for RGB (RGBA) versions

Accessories (as Contrast R0 except the honeycomb): die-cast aluminium ENAB44100 with textured grey powder coated finish
 Retaining screws: nickel plate brass
 Front glass: toughened glass

Installation/Mounting

Contrast LED is delivered complete with body and connection box including the power supply for the monochromatic versions or the power supply/DMX system for the RGB (RGBA) version.
 As the floodlight is pre-wired, the body must not be opened in order to preserve the electronic components. The distance between the power supply and the floodlight body is 60m maximum for the monochromatic versions and 50m for the RGB version (RGBA on request).

The floodlight is adjustable on a short, narrow stirrup which is fixed to mount by a central bolt hole 18mm diameter, and two 12mm diameter holes at 80mm either sides of centre. Aiming is simplified by an indicator and mark on stirrup, and locked via a central 8mm diameter Allen screw.

Plastic connection box must be opened for connections. Six retaining screws. Connect the Contrast floodlight to the connector in the gear box. Through wiring is supported.

To connect the RGB (RGBA) versions a DMX cable is required if dynamic scenario lighting effects are required. Connect the data +, data- and ground to the DMX connector.

Standards

Designed and manufactured to comply with EN60598
 ⬠ Class III electrical for the body alone
 ⬠ Class II electrical for the connection box
 ⬠ Class II electrical for floodlight + connection box
 IK08/5 N/m impact resistance for the body and the connection box
 ⚡ IP65 for the body
 ⚡ IP66 for the connection box
 ⚡ CE

Specification

To specify state:
 Shallow round LED floodlight for off set illumination on surface.
 Die-cast aluminium body and frame sealed IP65. With a choice of 5 monochromatic colours (2 whites, Red, Blue and Green) (Amber on request) and dynamic RGB employing LED light sources (RGBA on request), with remote connection box with power supply for monochromatic versions and power supply/DMX system for RGB/RGBA versions. Other DMX components ordered separately. As Contrast LED.

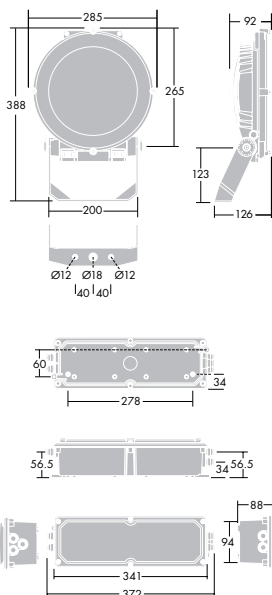

Ordering Guide

One code includes the Contrast LED with its connection box including power supply for the monochromatic versions or power supply + DMX system for the RGB version (RGBA version on request)

Description	Weight (Kg)	SAP code
Monochromatic versions		
CONTRAST LED 86,6W 240V 54LED WHI/6000K	6.3	96254292
CONTRAST LED 86,6W 240V 54LED WHI/3000K	6.3	96254293
CONTRAST LED 86,6W 240V 54LED BLU	6.3	96254294
CONTRAST LED 60W 240V 54LED RED	6.3	96254267
CONTRAST LED 86,6W 240V 54LED GRN	6.3	96254268
RGB version		
CONTRAST LED 51,6W 240V 36LED RGB DMX	7.0	96254269



OMS - semi-intensive prismatic glass



LR1 - medium wide refractor



Wire guard



Chromatic correction filter



OMP - semi-extensive prismatic glass



LR2 - wide refractor



Adjustable anti glare louvre



Barn door



OMW - extensive prismatic glass



LR3 - narrow refractor



Fixed louvre



Visor



OME - super extensive prismatic glass

Accessories Ordering Guide

A wide selection of attachments can be fixed on the Contrast LED front. The accessories can be superimposed and used with prismatic glasses or refractors to offer a variety number of light effects. All adjustments can easily be made on site.

Description		Weight (Kg)	SAP code
CONT R0 GL/FR S/S SINT (OMS)	Semi-intensive symmetrical	1.0	96002503
CONT R0 GL A/S SINT (OMP)	Semi-extensive asymmetrical	1.0	96002504
CONT R0 GL A/S EXT (OMW)	Extensive asymmetrical	1.0	96002505
CONT R0 GL S/S XEXT (OME)	Super extensive symmetrical	1.0	96002506
CONT R0 LR1	Medium wide refractor	1.0	96002500
CONT R0 LR2	Wide refractor	1.0	96002501
CONT R0 LR3	Narrow refractor	1.0	96002502
CONTRAST R0 GL CHROMAT CORRECTION FILTER	Warmer glass LEE filter 205	1.0	96254526
CONT R0 WG	Wire guard	1.0	96002511
CONT R0 LV	Fixed anti glare louvre	0.7	96002508
CONT R0 LV/AJ	Adjustable anti glare louvre	0.7	96005841
CONT R0 AGF	Spill light controller	1.0	96216220
CONT R0 VS	Visor	0.4	96002516
CONTRAST CO/R0 AGS (x1)	Barn door (x1)	1.0	96002507

THORN

Lighting people and places

Thorn Lighting Main Offices

Thorn Academy of Light

Green Lane Industrial Estate, Spennymoor
County Durham DL16 6HL, UK
Tel: (44) 1388 420 042
E-mail: academy@thornlighting.com
Website: www.thornacademyoflight.com

Australia

Thorn Lighting Pty Limited
43 Newton Road, Wetherill Park
NSW 2164
Tel: (02) 8786 6000
Fax: (02) 9612 2700
E-mail: infoaustralia@thornlighting.com
Website: www.thornlighting.com.au

Austria

Thorn Licht GmbH
Donau-City-Straße 1,
1220 Wien, Austria
Tel: (43) 1 202 66 11
Fax: (43) 1 202 66 11 82712
E-mail: office.at@thornlighting.com
Website: www.thornlighting.at

China

Thorn Lighting (Guangzhou) Operations Ltd,
No.12 Lian Yun Road, Eastern Section,
GETDD, Guangzhou 510530, China
Tel: (86) 20 3228 2706
Fax: (86) 20 3228 1777
E-mail: sales.cn@thornlighting.com

Thorn Lighting (Tianjin) Co. Ltd
332 Hongqi Road, Tianjin 300190,
China
Tel: (86) 22 8369 2303
Fax: (86) 22 8369 2302
E-mail: info.tj@thornlighting.com

Czech Republic

Thorn Lighting CS spol. s.r.o.,
Na Březince 6/930, 150 00 Praha 5
Czech Republic
Tel: (420) 224 315 252
Fax: (420) 233 326 313
E-mail: thorn.cz@thornlighting.com
Website: www.thornlighting.cz

Denmark

Thorn Lighting A/S
Kanonbådsvej 12B, Holmen,
1437 København K, Denmark
Tel: (45) 76 96 36 00
Fax: (45) 76 96 36 01
E-mail: info.dk@thornlighting.com
Website: www.thornlighting.dk

France

Thorn Europhane SA
156 Boulevard Haussmann,
Cedex 08, Paris 75379, France
Tel: (33) 1 49 53 6262
Fax: (33) 1 49 53 6240
Website: www.thornlighting.fr

Hong Kong

Thorn Lighting (Hong Kong) Limited
Unit 4301, Level 43, Tower 1,
Metropolaza, 223 Hing Fong Road,
Kwai Chung, N.T., Hong Kong
Tel: (852) 2578 4303
Fax: (852) 2887 0247
E-mail: info.hk@thornlighting.com

India

Thorn Lighting India Pvt. Ltd.
501, 5th Floor, Tanishka
Opp. Gundecha Industrial Estate
Akurli Road, Kandivali (E), Mumbai – 400 101, India
Tel: (91) 22-67839100
Fax: (91) 22-67839106
E-mail: international_sales@thornlighting.com
Website: www.thornlighting.com

International Sales

Thorn Lighting Limited
Silver Screens, Elstree Way, Borehamwood,
Hertfordshire, WD6 1FE, UK
Tel: (44) 20 8732 1915
Fax: (44) 20 8732 1911
E-mail: international_sales@thornlighting.com
Website: www.thornlighting.com

Ireland

Thorn Lighting (Ireland) Limited
Century House
Harolds Cross Road
Dublin 6W
Tel: (353) 1 4922 877
Fax: (353) 1 4922 724
E-mail: dublinsales@thornlighting.com
Website: www.thornlighting.co.uk

Italy

Thorn Europhane Spa
Via G Di Vittorio, 2, Cadriano di Granarolo,
Bologna 40057, Italy
Tel: (39) 051 763391
Fax: (39) 051 763088
E-mail: info@thornlighting.it
Website: www.thornlighting.it

New Zealand

Thorn Lighting (NZ) Ltd
399 Rosebank Road, Avondale, Auckland 1026
PO Box 71134, Rosebank, Auckland 1348
Tel: (64) 9 828 7155
Fax: (64) 9 828 7591
E-mail: info.NZ@thornlighting.com
Website: www.thornlighting.co.nz

Norway

Thorn Lighting AS
Strømsveien 344, 1081 Oslo,
Norway
Tel: (47) 22 82 07 00
Fax: (47) 22 82 07 01
E-mail: info.no@thornlighting.com
Website: www.thornlighting.no

Poland

Thorn Lighting Polska Sp.z.o.o.,
Ul. Gazowa 26A, Wrocław 50-513,
Poland
Tel: (48) 71 7833 740
Fax: (48) 71 3366 029
E-mail: thorn.pl@thornlighting.com
Website: www.thornlighting.pl

Russia

Thorn Lighting
Novoslobodskaya Str., 21, office 406
Business Center "Novoslobodskaya 21",
Moscow 127030, Russia
Tel: (7) 495 981 35 41
Fax: (7) 495 981 35 42
E-mail: kristina.skachinskaya@thornlighting.com
Website: www.thornlighting.ru

Singapore

Thorn Lighting (Singapore) Pte Ltd
5 Kaki Bukit Crescent, 04-02 Koyotech
Building, 416238 Singapore
Tel: (65) 6844 5800
Fax: (65) 6745 7707
E-mail: info.sg@thornlighting.com

Sweden

Thorn Lighting AB
Industrigatan, Box 305, SE-261 23
Landskrona, Sweden
Tel: (46) 418 520 00
Fax: (46) 418 265 74
E-mail: info.se@thornlighting.com
Website: www.thornlighting.se

United Arab Emirates

Thorn Lighting Ltd Dubai
Al Shoala Building, Office 301,
Block E, Airport road, P.O. Box 1200,
Deira, Dubai, UAE
Tel: (971) 4 2940181
Fax: (971) 4 2948838
E-mail: illuae@emirates.net.ae
Website: www.thornlighting.com

Thorn Gulf LLC

Al Shoala Building, Office 301/2, Block E,
Airport road, P.O. Box 22672, Deira,
Dubai, UAE
Tel: (971) 4 2948938
Fax: (971) 4 2948838
E-mail: thornng@emirates.net.ae
Website: www.thornlighting.com

United Kingdom

Thorn Lighting Limited
Silver Screens, Elstree Way, Borehamwood,
Hertfordshire, WD6 1FE, UK
Tel: (44) 20 8732 9800
Fax: (44) 20 8732 9801
E-mail: brochures.uk@thornlighting.com

Thorn Olympics Sports Lighting Team

Tel: 07785 251 438
E-mail: olympics.team@thornlighting.com
Website: www.thornlighting.co.uk

www.thornlighting.com

Thorn Lighting is constantly developing and improving its products. All descriptions, illustrations, drawings and specifications in this publication present only general particulars and shall not form part of any contract. The right is reserved to change specifications without prior notification or public announcement. All goods supplied by the company are supplied subject to the company's General Conditions of Sale, a copy of which is available on request. All measurements are in millimetres and weights in kilograms unless otherwise stated.

Publication No: 446 (INT) Publication Date: 07/09